

794SL-BL

Smart Lighting Control | SMART CONTROL - LIGHTING & AUDIO RANGE | Smart Control Plates

Item Image



Wiring



Dimensions

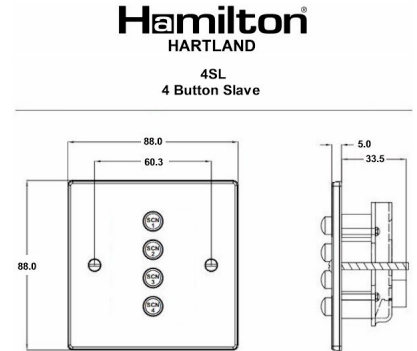

Primary Range	Smart Lighting Control	
Insert Type	Smart Lighting Control - 4 Button Slave	
Insert Colour	Black	
EAN13 Barcode	5052750002402	
Commodity Code	85371098	
Luckins TSI	400664567	
Dimensions(Nominal)	Single: Height = 88.0mm Width = 88.0mm Depth = 5.0mm	
Current Rating	n/a	
Voltage	12V	
Standard/Approval	IEC 60065 + EN 55022:2006	
All products listed conform to current British or European standard and the product information is correct at the time of going to press.	All accessories are manufactured under an accredited BS EN ISO 9001 : 2015 Quality Management System.	It is the policy of the company to improve products as part of our development programme. Therefore, we reserve the right to alter designs and dimensions without prior notice.
Illustrations and diagrams are reproduced within the limitations of reproduction and printing process and are not binding.	Due to manufacturing processes we cannot guarantee an exact colour match and shadings of of certain finishes.	Correct as at 17 May 2022 06:45 PM E&OE

794SL-BL

Smart Lighting Control | SMART CONTROL - LIGHTING & AUDIO RANGE | Smart Control Plates

R Hamilton & Co Ltd, Unit 10 Carrick Business Centre, 4-5 Bonville Road,
Brislington, Bristol, BS4 5NZ

T: +44 (0)1747 860088

E: info@hamilton-litestat.com www.hamilton-litestat.com

Registered Office 1 Rushmills, Bedford Road, Northampton NN4 7YB

Registered in London No. 941624 VAT Registration No. 222 6607 84



794SL-BL - Smart Lighting Control - Hartland Antique Brass - 4 Button Slave Black